

**Title:**            Creating Design Hierarchy

**Product:**        OrCAD PSpice A/D, OrCAD PSpice AA  
                      and AMS Simulator

**Summary:**        This application note shows you how to  
                      create a hierarchical block using bottom-up  
                      or top-down method for your PSpice  
                      project

**Author/Date:** Wei Ling / 24.08.2010

---

## Table of Contents

1	Introduction .....	2
2	Creating a Schematic for a Hierarchical Block.....	2
3	Creating Hierarchical Blocks .....	3
4	Simulation of the Hierarchical Design.....	7
5	Bibliography .....	8

# 1 Introduction

A hierarchical block can be used as a representation of a schematic folder, which is attached to the hierarchical block. It provides vertical (downward-pointing) connection only.

The hierarchical pins in a hierarchical block act as points of attachment for electrical connections between the hierarchical block and other connectivity objects in the attached schematic folder. A hierarchical block functions just like a part with an attached schematic folder.

# 2 Creating a Schematic for a Hierarchical Block

As an example we would like to build up a B6 bridge rectifier for a three-phase electric power supply. Create a schematic named e.g. b6\_bottom\_up and build a circuit as follows:

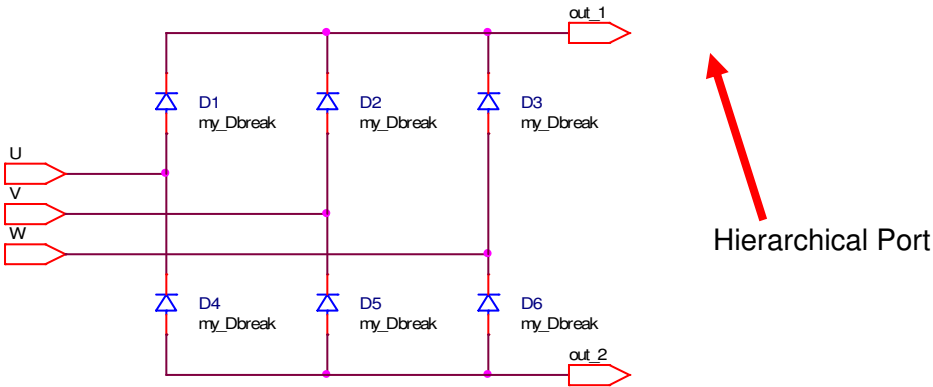

You must use the hierarchical port to define the pins of a hierarchical block. The ports are placed on nodes in the lower level schematic that will be pins on the upper level block symbol. If the schematic is active, you can access the hierarchical port through

**Place → Hierarchical Port... → A Place Hierarchical Port window comes up:**

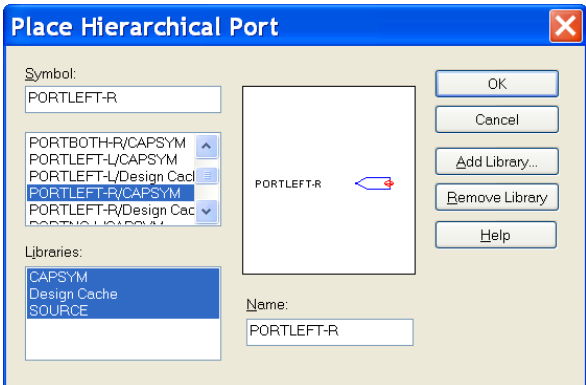

In the **Place Hierarchical Port** window you can choose the hierarchical port which you want to use in your schematic.

### 3 Creating Hierarchical Blocks

Creating a schematic named e.g. root and making it as root schematic.

**First, we can generate a hierarchical block based on the schematic view b6\_bottom\_up. This is the so called bottom-up method.**

Activate the schematic page, then in menu bar click **Place** → **Hierarchical Block...** → The **Place Hierarchical Block** dialog box appears.

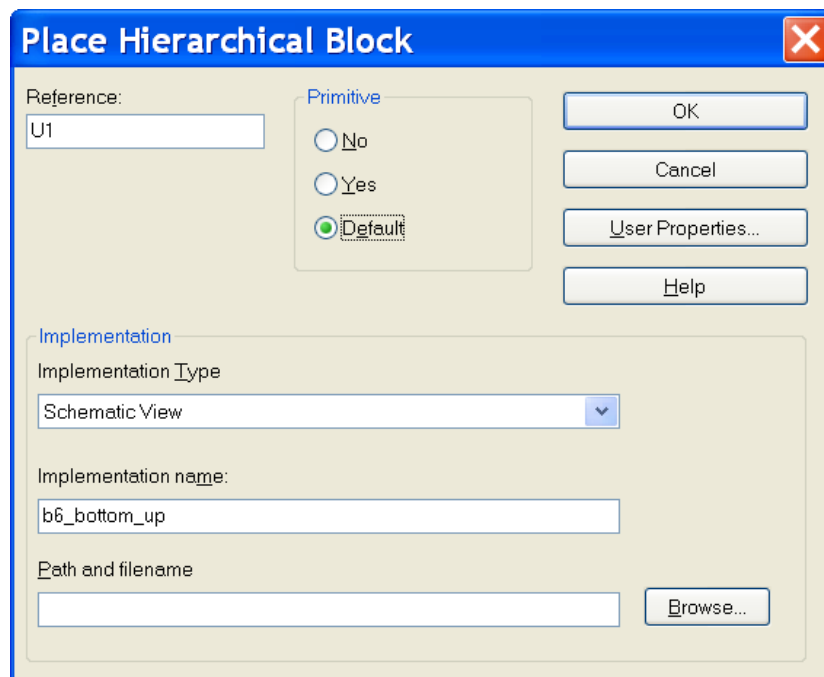

Give the **Reference** a name e.g. U1. This is the name of the hierarchical block.

The “Default” is used for default primitive setting, which for hierarchical blocks is nonprimitive. The default setting for hierarchical blocks is set in the Hierarchy tab of the Design Template dialog box. The nonprimitive enables you to descend in hierarchy.

Use “Schematic View” as **Implementation Type**. The Schematic View indicates that the attached implementation is a schematic folder. Capture automatically generates the appropriate hierarchical pins for the block based on the hierarchical ports.

**Implementation name** specifies the name of the attached schematic folder. Here you should use the name “b6\_bottom\_up”.

You can just leave the option **Path and filename** unspecified because the attached schematic folder is in the same design as the hierarchical block you are placing.

**Note:**

If you attach external schematic folders or other files to hierarchical blocks in a design or parts in a library, be sure to include the attachments when you pass the design or library to a board fabrication house or to another engineer. Attached schematic folder and other files are not carried along automatically when you copy or move a part, schematic folder, or

schematic page to another library, design, or schematic folder. Only the "pointers" to the attached schematic folder and files—that is, their names and the names of the designs or libraries that contain them—are carried along.

Click OK → draw a rectangle on the schematic page. If necessary, you can of course change the shape and modify the pin for the hierarchical block.

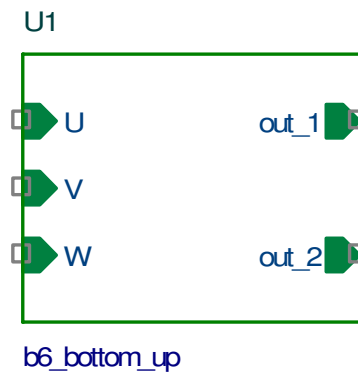

**Second, we can generate a hierarchical block to represent a three-phase electric power supply using the so called top-down method.**

Make sure the root schematic is active. Click **Place** → **Hierarchical Block...** → Set the **Place Hierarchical Block** dialog box as follows:

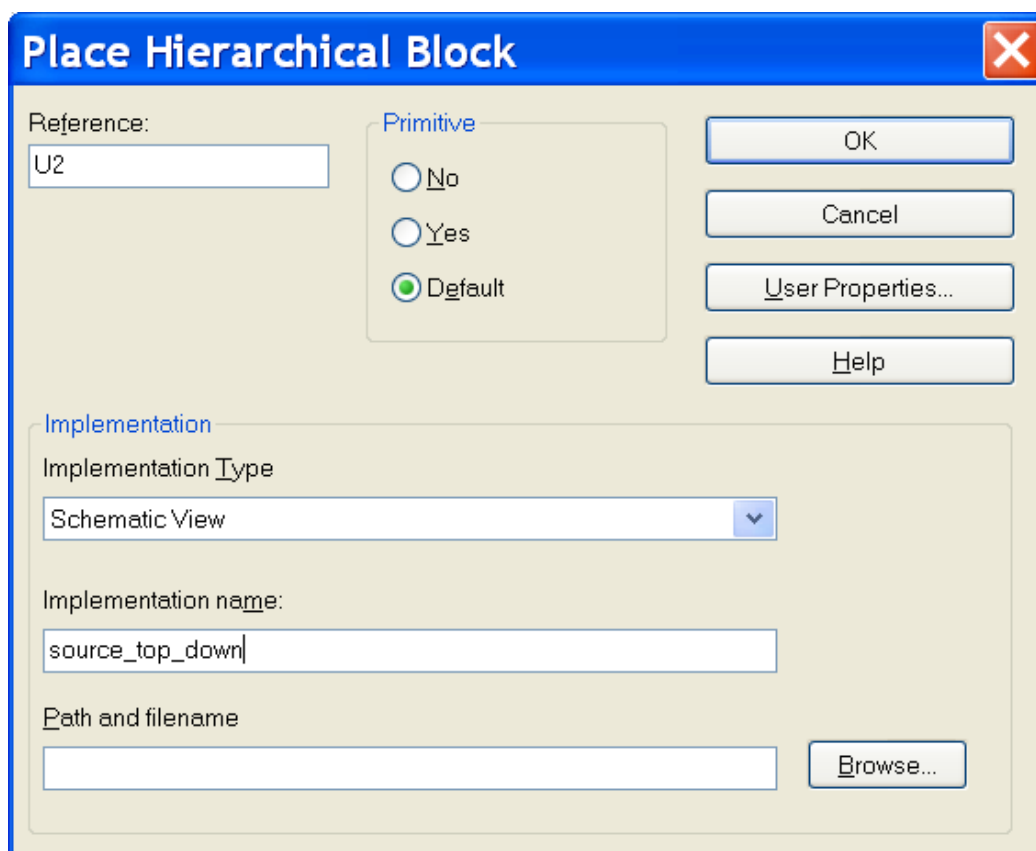

Click **OK** and draw a rectangle on the schematic page. You will see the reference name U2 and the implementation name source\_top\_down for the hierarchical block.

U2



source\_top\_down

Double click to descend this hierarchical block. A dialog box appears to allow you to specify a name for new page in schematic source\_top\_down.

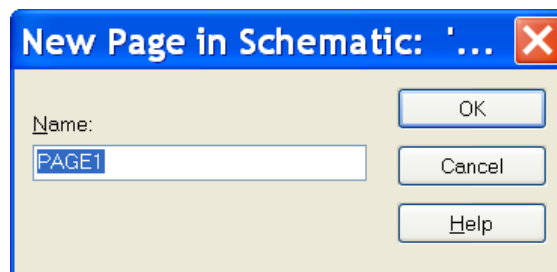

Click **OK** → A new page appears to allow you to build your circuit.

#### Note:

If you don't specify a full path and filename for the hierarchical block, Capture expects to find the attached schematic folder in the same design as the part of hierarchical block to which it is attached. If the specified schematic folder doesn't exist in the design, Capture creates the schematic folder when you descend hierarchy on the hierarchical block.

Build up the power supply as follows and set the PHASE=0 for V1, PHASE=120 for V2 and PHASE= 240 for V3.

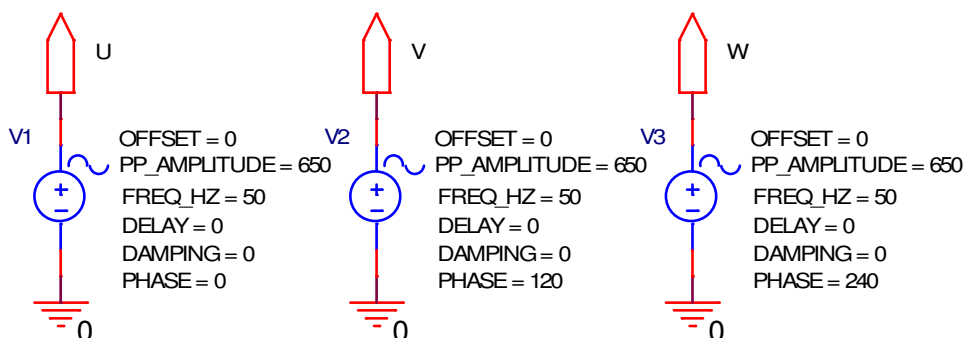

Click anywhere on this page with the right mouse button, in pop up menu choose the command **Ascend Hierarchy** to go back to the upper lever schematic page.

We have already defined the pins (hierarchical ports in associated schematic page) for the hierarchical block, now we need to make the pins visible. Select U2 and click the right mouse

button, in pop up menu use the command **Synchronize up** to synchronize the hierarchical block with the attached schematic folder `source_top_down`. If necessary, modify the graphical symbol and the hierarchical pins as follows.

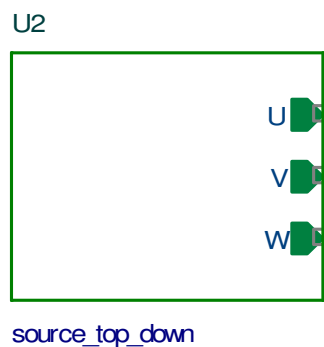
**Note:**

If you attach an existing schematic folder to a hierarchical block, Capture automatically creates the hierarchical pins that correspond with the schematic folder's hierarchical ports (bottom-up).

If you descend hierarchy on a hierarchical block whose schematic folder doesn't yet exist, then Capture automatically creates the hierarchical ports that correspond with the hierarchical pins of the hierarchical block(top-down).

## 4 Simulation of the Hierarchical Design

Build the circuit as follows:

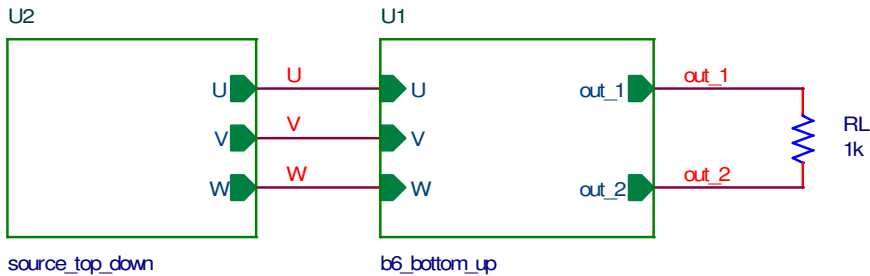

Run the simulation, for example, for 60ms. In probe window add the voltage curves for the three-phase electric power supply U, V and W.

For each phase, the peak-to-peak amplitude is 650V. According to the following functions

$$\hat{V} = \frac{PP\_AMPLITUDE}{2} = \frac{650V}{2} = 325V \tag{1}$$

$$V_{eff} = \frac{1}{\sqrt{2}} \hat{V} \tag{2}$$

Where:

$\hat{V}$  is the peak voltage

$V_{eff}$  is the effective voltage

We can get the effective voltage for each phase. It is

$$V_{eff} = \frac{1}{\sqrt{2}} \hat{V} = \frac{1}{\sqrt{2}} 325V \approx 230V$$

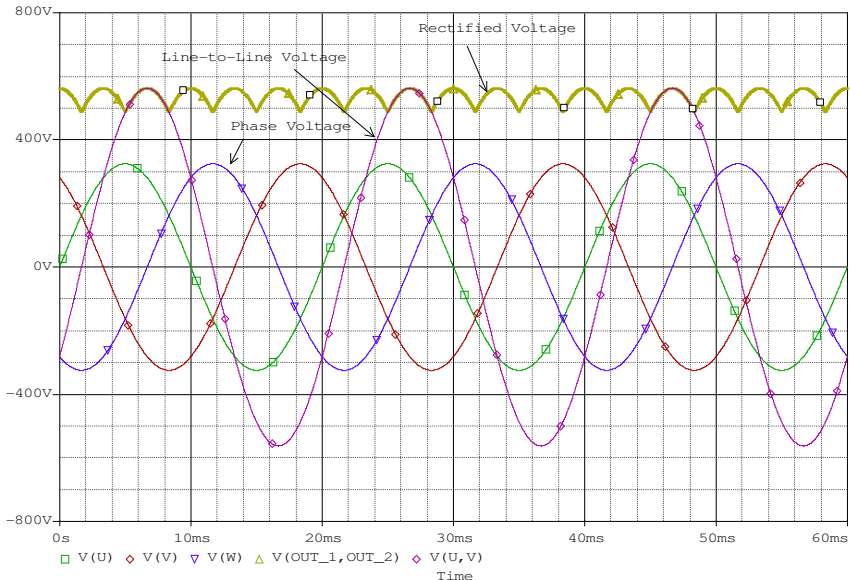

The rectified voltage  $V(\text{OUT}_1, \text{OUT}_2)$  is also displayed in the above diagram. It has 6 pulses in one period.

The peak value of the line-to-line voltage e.g.  $V(U, V)$  can be calculated using the following function

$$\hat{V}(U, V) = \sqrt{3} \hat{V}(U) = \sqrt{3} \hat{V}(V) = \sqrt{3} \times 325 \approx 563V \quad (3)$$

Therefore the effective value of the line-to-line voltage is

$$V_{eff} = \frac{1}{\sqrt{2}} \hat{V} = \frac{1}{\sqrt{2}} 563V \approx 400V$$

The peak amplitude of the rectified voltage is equal to the peak amplitude of the line-to-line voltage. It is 563V too.

For a periodical signal e.g. a voltage, the average value can be calculated using the following function

$$\bar{V} = V_{av} = \frac{1}{T} \int_{t_0}^{t_0+T} v(t) dt \quad (4)$$

Therefore the average value of the rectified voltage can be calculated as follows:

$$V_{av} = \frac{1}{\frac{\pi}{6} - (-\frac{\pi}{6})} \int_{-\frac{\pi}{6}}^{\frac{\pi}{6}} \hat{V} \cos(\omega t) d(\omega t) \quad (5)$$

$$V_{av} = \hat{V} \frac{3}{\pi}$$

From function (1) we get

$$V_{av} = 537V$$

## 5 Bibliography

- [1] PSpice User's Guide, Cadence
- [2] OrCAD Capture User's Guide, Cadence
- [3] Leistungselektronische Schaltungen, D. Schröder, Springer